

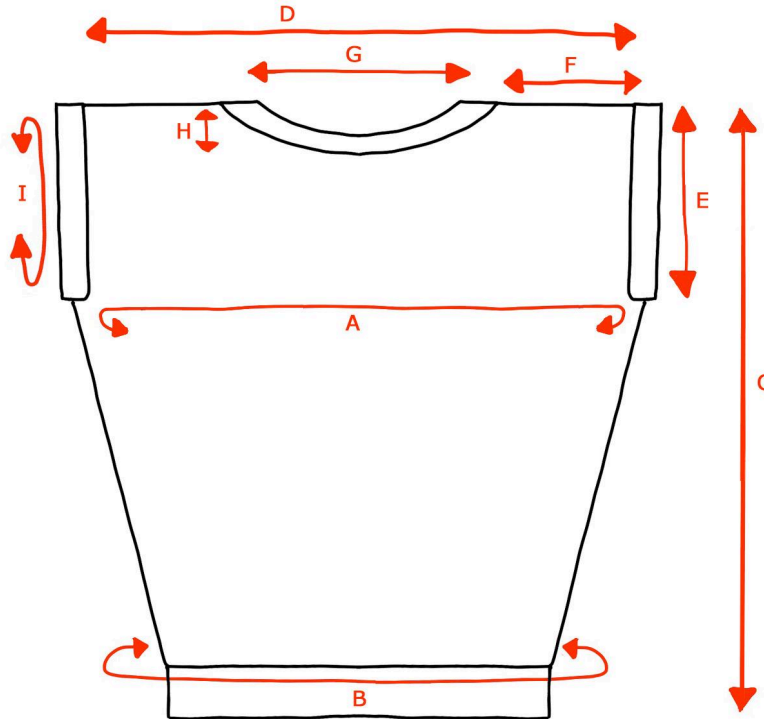

SCHEMATIC FILE FOR REFERENCE



Pattern Finished Measurements in inches

A - Full bust circumference	30.25	33.75	36.25	39.5	43	46.25	49.25	52.25	55.5	59	63.5
B - Waist circumference	23.5	26.5	29.5	32.5	35.75	39.5	42.5	45.5	48.5	52.25	56
C - Body length	18.25	18.75	18.5	19	19	19	19.25	20	20.5	20.75	21
D - Cross back width	15	16.25	17.5	17.75	18.25	18.5	19.5	19.75	20	21.25	21.75
E - Armhole depth	6	6.25	6.5	7	7.25	7.75	8	8.5	8.75	9	9.25
F - Shoulder width (modified dropped)	4.25	4.75	5.5	5.5	5.5	5.5	5.75	5.75	5.75	6.25	6.25
G - Back neck width	6.75	6.75	6.75	7	7.5	7.75	8	8.25	8.5	9	9.5
H - Front neck depth	3.25	3.25	3.25	3.25	3.25	3.5	3.5	3.5	4	4.5	4.75
I - Upper arm circumference (for sleeve bands)	11	11.75	13	13.5	14.5	15.75	16.25	17	17.75	19.75	20

Pattern Finished Measurements in centimeters

A - Full bust circumference	77	85.5	92	100.5	109	117.5	125	132.5	141	150	161.5
B - Waist circumference	59.5	67.5	75	82.5	91	100.5	108	115.5	123	132.5	142
C - Body length	46.5	47.5	47	48.5	48.5	48.5	49	51	52	52.5	53.5
D - Cross back width	38	41.5	44.5	45	46.5	47	49.5	50	51	54	55
E - Armhole depth	15	16	16.5	18	18.5	19.5	20.5	21.5	22	23	23.5
F - Shoulder width (modified dropped)	11	12	14	14	14	14	14.5	14.5	14.5	16	16
G - Back neck width	17	17	17	18	19	19.5	20.5	21	21.5	23	24
H - Front neck depth	8.5	8.5	8.5	8.5	8.5	9	9	9	10	11.5	12
I - Upper arm circumference (for sleeve bands)	28	30	33	34.5	37	40	41.5	43	45	50	51

