

Razzler Top

by Tasha Moss

SCHEMATIC FILE FOR REFERENCE

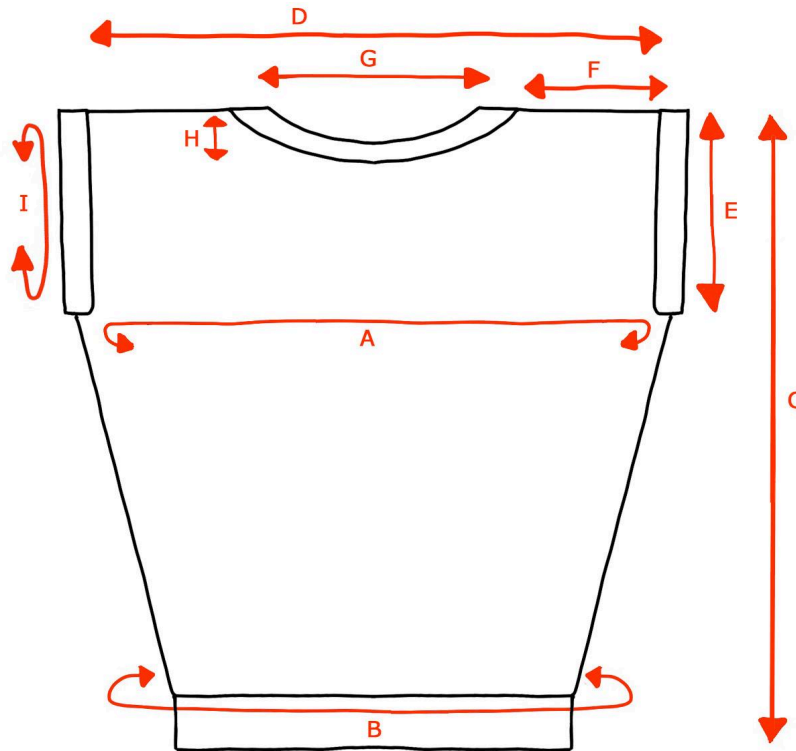

Pattern Finished Measurements in inches

A - Full bust circumference	29.75	33.25	36	38.75	42.25	45	48.5	52	54.75	58.25	61
B - Waist circumference	23.5	26.25	29	32.5	36	38.75	42.25	45.75	48.5	52	54.75
C - Body length	18.25	18.25	18.5	19	19.25	19.25	19.75	20	20.5	20.5	21
D - Cross back width	15	16	17.25	17.75	17.75	18.25	19	19.5	19.5	20	20
E - Armhole depth	5.75	6	6.25	6.5	7.25	7.5	7.75	8	8.25	8.75	8.75
F - Shoulder width (modified dropped)	4.25	4.5	5	5	5	5	5.25	5.25	5	5.25	5
G - Back neck width	6.75	7	7.5	7.5	8	8	8.5	9	9.25	9.25	9.75
H - Front neck depth	2.5	2.5	2.5	2.5	2.5	2.5	2.5	2.5	2.75	2.75	2.75
I - Upper arm circumference (for sleeve bands)	11.5	13	13.75	14.25	15.5	17	17.75	17.75	19	21.75	21.75

Pattern Finished Measurements in centimeters

A - Full bust circumference	75.5	84.5	91.5	98.5	107.5	114.5	123	132	139	148	155
B - Waist circumference	59.5	66.5	73.5	82.5	91.5	98.5	107.5	116	123	132	139
C - Body length	46.5	46.5	47	48.5	49	49	50	51	52	52	53.5
D - Cross back width	38	40.5	44	45	45	46.5	48.5	49.5	49.5	51	51
E - Armhole depth	14.5	15	16	16.5	18.5	19	19.5	20.5	21	22	22
F - Shoulder width (modified dropped)	11	11.5	12.5	12.5	12.5	12.5	13.5	13.5	12.5	13.5	12.5
G - Back neck width	17	18	19	19	20.5	20.5	21.5	23	23.5	23.5	25
H - Front neck depth	6.5	6.5	6.5	6.5	6.5	6.5	6.5	6.5	7	7	7
I - Upper arm circumference (for sleeve bands)	29	33	35	36	39.5	43	45	45	48.5	55	55